

MULTI-PORT CONVERTERS FOR MV APPLICATIONS

Modeling, and control of multiport power converters for medium voltage application has been discussed in iPLUG, where two distinct multiport converter (MPC) topologies, isolated and non-isolated alternatives have been considered.

The various components that make up the converters were described and the operation of the converters in different operation conditions were also demonstrated.

ISOLATED MPC

Isolated MPC configurations for MV applications are based on the Solid-State Transformers (SSTs) or Smart Transformer concept.

A three-port configuration is presented in the project as shown in Fig. 1. The three ports are interconnected by a high-frequency DC-DC converter stage to provide both isolation between the ports as well as a dc-port connection point for integration of energy storage or photo-voltaic (PV) source. The modular multilevel converter to make up the medium voltage ac-ports are based on full-bridge (FB) modules.

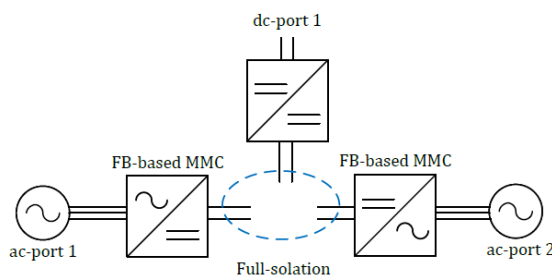

Fig. 1: Schematic of isolated MPC configuration

The isolated MPC converter to be studied further consists of two ac-ports constituted by CHB-based MMC as shown in Fig.2 and an isolation stage based on high-frequency DC-DC converters with multiple-active bridges (MAB) per module. The dc-port is also generated from the isolation stage as indicated in Fig. 3, where an extra dc-dc stage can be added to obtain the voltage level to connect a source or load.

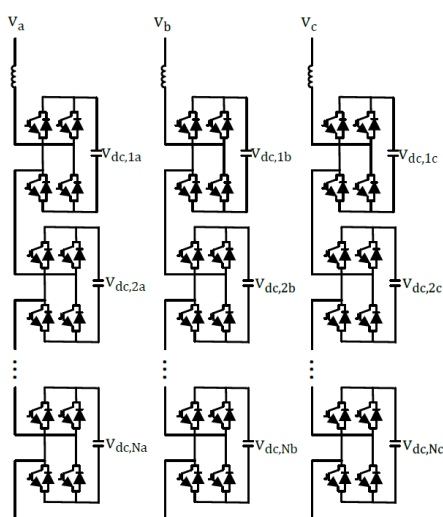

Figure 2: Detailed schematic of a 3-phase MMC with N CHB-based submodules

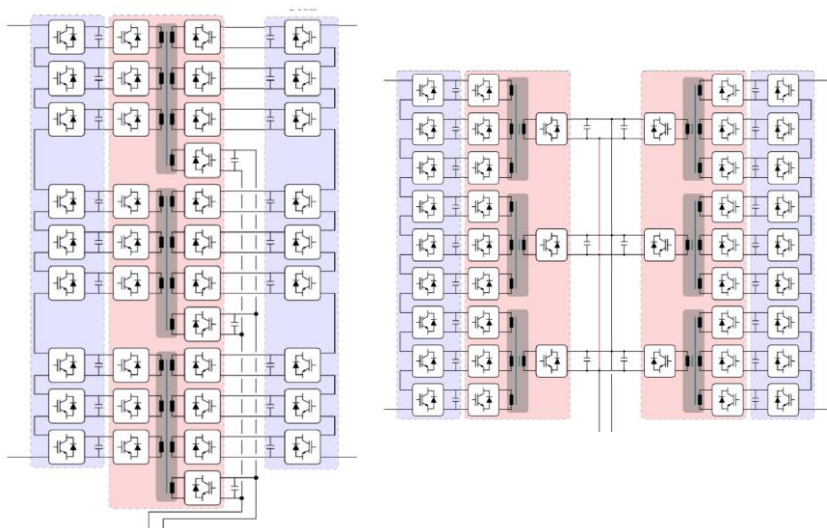

Figure 3: Detailed schematic of two alternative implementation of one phase of the isolated MPC

Control Strategies

The three-phase MMC is controlled using the classical approach of grid-following control on the ac-side in a synchronous dq-reference frame, with the following structures, Q/Vac control, P/Vdc control, current control, individual and cluster cell balancing and modulation.

The Multiple active bridge DC/DC converter (in this case a triple active bridge) presents various alternatives for the control. Among these, the use of phase-shift modulation with a fixed 50% duty-cycle ac-voltage on the primary and secondary side of the transformer to operate the full-bridge converters is the simplest and the most common. On the modulation scheme, two alternatives of bipolar and uni-polar switching schemes to generate a square wave and quasi-square wave ac-voltages on the primary side are implemented. The secondary side converters will be modulated similarly by applying a phase shift to the primary switching patterns base on the implemented control. The uni-polar scheme is used to minimize the total harmonic content in the input and output sides of the transformer. The harmonics content is improved with uni-polar switching without affecting the power transfer capability significantly and hence adds an advantage.

Modulation strategies of MMC stage: As shown in Fig.4, by using alternated level-shifted carriers, the number of output voltage levels can be improved.

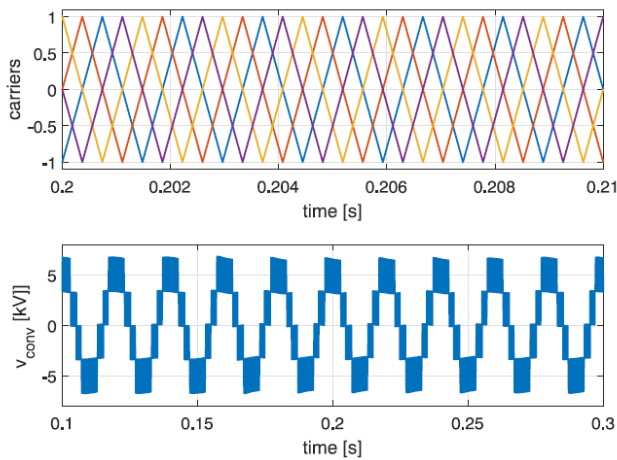

Figure 4: Carrier (top) signals to generate the PWM output voltage (bottom) of the MMC for phase.

Modulation strategies of DC-DC converter stage: phase-shifted bipolar operation (bipolar or unipolar) of the MAB. Example of bipolar operation is shown in Fig.5.

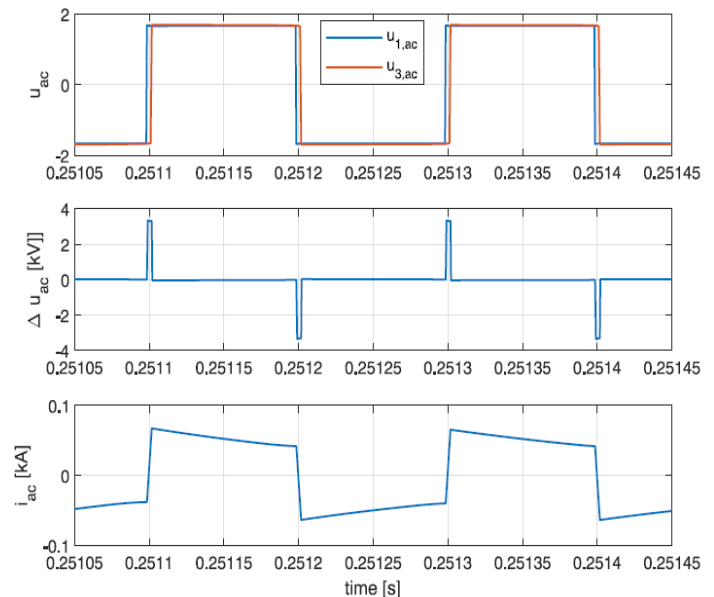

Figure 5: Bipolar switching MAB operation; input voltage to the winding 1 and 3 of the MAB (top), the corresponding differential voltage on the leakage inductance (middle) and the resulting current on winding 1 (bottom).

NON-ISOLATED MPC

The non-isolated MPC topology studied in the project has 2 AC/DC ports based on Modular Multilevel Converters (MMC) and 1 DC load which may be directly connected to the DC bus. The MPC has been studied in a system in which both MMCs are connected at the same AC grid by two identical feeders, because of the challenges that this system has when AC faults happen.

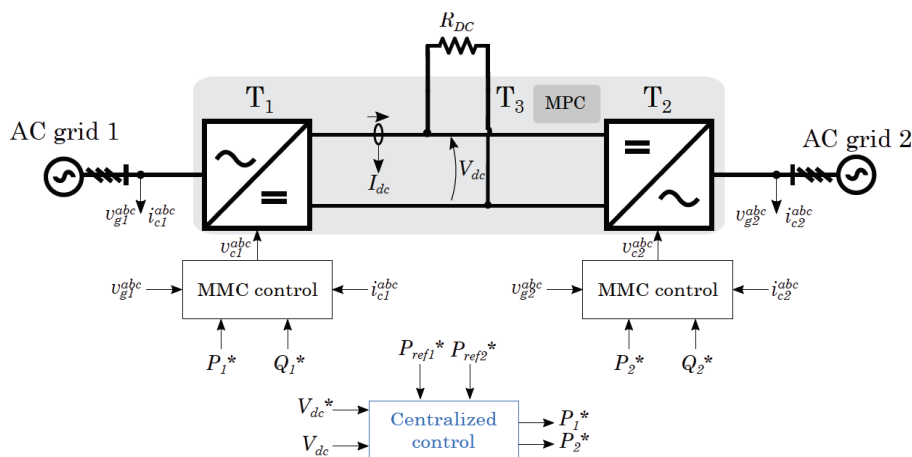

Figure 6: General schematic of the MPC control.

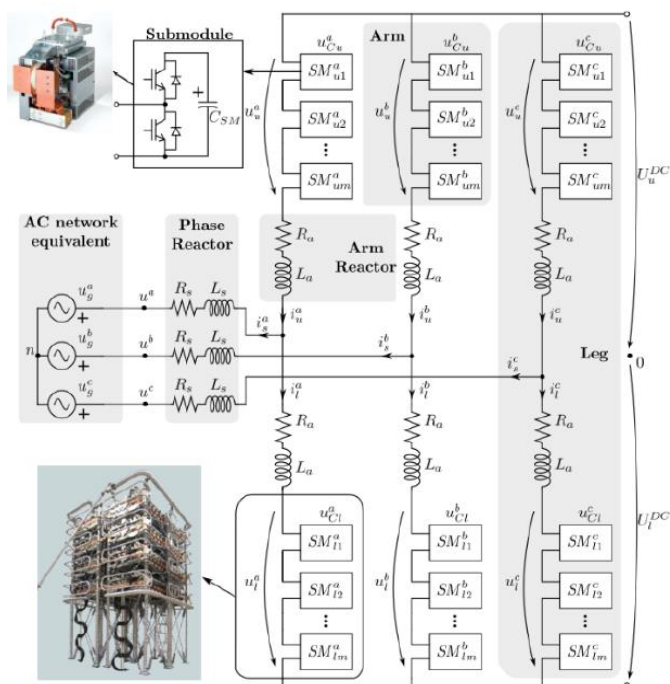

Figure 7: Equivalent circuit of a three-phase MMC

The control of the presented non-isolated MPC is shown in Figure 6. An MMC is a Voltage Source Converter (VSC) structure which could be an interesting solution in Medium Voltage (MV) and High Voltage (HV) grids. This converter uses submodules in series in which each sub-module has IGBTs in a half-bridge or full-bridge structure. Figure 7 shows a schematic of an MMC with half-bridge submodules.

Control Strategies

The control architecture could be defined on two blocks: the energy control and the grid control. Unlike other VSCs, as 2-level converters, energy control is essential on MMCs, because if it is not controlled, the energy of the capacitors of the submodules would not be balanced.

The calculation of the references of each of the currents used to control both parts is essential, as each of them can be obtained from the AC part or the DC part. A centralized DC voltage control is used to ensure FRT capabilities in a wide range of faults, as the ports that participate in the control of the DC bus can be chosen.

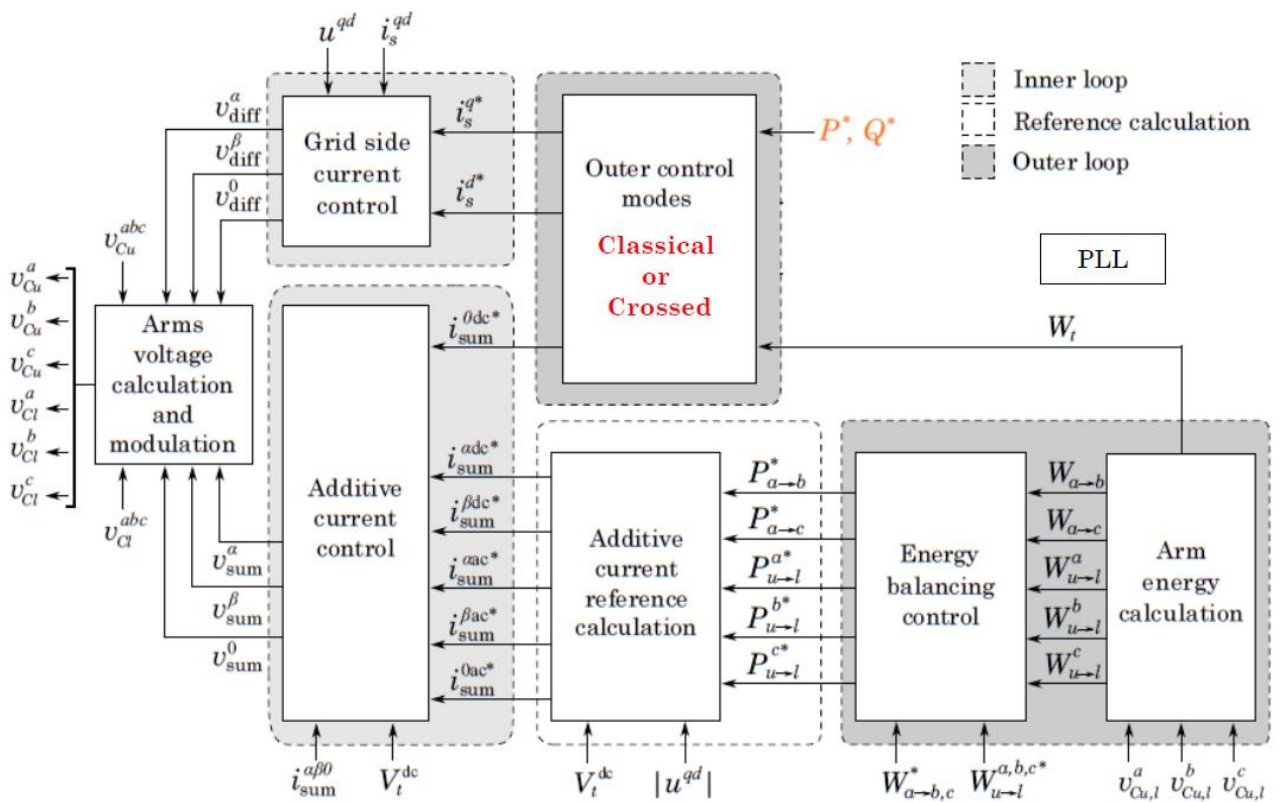

Figure 8: General control of an MMC.

The general control structure of the MMC is defined in Figure 8. The outer loop is defined according to the following approaches, which affect the DC voltage and energy controls:

- **Classical control:** the grid (differential) current is related to the DC voltage control (active power), while the additive current is related to the energy control.
- **Crossed control:** the additive current is related to the DC voltage control, while the grid current is related to the energy control.

EVENTS

03 General Assembly

In April 2024, the third General Assembly of the project iPLUG was hosted by IREC - Institut de Recerca en Energia de Catalunya in Sant Adria de Besòs and Anell in Granollers. During the first day at IREC - Institut de Recerca en Energia de Catalunya, there was an extensive review of the Work Packages and technical discussions regarding multiport converters sizing and topologies for medium voltage applications with the main focus on the upcoming midterm review preparations for each beneficiary. Later on, during the day, we had the opportunity to visit IREC - Institut de Recerca en Energia de Catalunya Laboratory known as IREC's Energy Smart Lab. After the visit a dinner was organized by IREC - Institut de Recerca en Energia de Catalunya where all the participants had the opportunity to network and share their experiences so far during the implementation of the project iPLUG. On the second day at Anell discussions and sessions regarding WPs were held by Università degli Studi di Padova, IREC - Institut de Recerca en Energia de Catalunya, CITCEA-UPC and Anell. Later on, the attendees had the opportunity to visit Estabanell's offices, continuing with a visit at COX, the Control Center and CT Torres iBages, the Transformation Center.



HVDC Colloquium 2024

CITCEA-UPC presented this February at the HVDC Colloquium held at ETSEIB, UPC. This colloquium was organized by Universitat Politècnica de Catalunya, KU Leuven, Imperial College London, Cardiff University / Prifysgol Caerdydd and Centrale Lille and it was a great opportunity to share research between academics in the electronic grid field and more specifically in the HVDC field.

CITCEA-UPC presented their progress in the iPLUG project with a presentation entitled "Comparison of control strategies for a non-isolated MMC Multiport Converter", in which a comparison in abnormal grid conditions between two different control architectures of a Multiport Converter based on Modular Multilevel Converters (MMCs) was presented.



TYPHOON-HIL visits IREC & CITCEA-UPC

In April 2024, Sergio Costa from Typhoon-Hil visited IREC and CITCEA-UPC. During his first visit at IREC, a 1-hour tour of IREC's labs was organized following a discussion of the hardware and software capabilities for hardware in the loop (HIL) testing. The main focus was on the hardware tools which are available for TyphoonSim software for offline testing in collaboration with IREC, CITCEA-UPC and UoS on the development of the grid model in WP4. During the second visit at UPC a 40-minute seminar was organized by CITCEA-UPC working group where Sergio Costa from Typhoon-Hill presented different methodologies of design, software in the loop and hardware in the loop (HIL) testing which are often encountered with its industry customers.

This was a great opportunity to share the capabilities of the remote Hardware in the loop testbed available in the iPLUG project with a focus on validation for Microgrid applications.

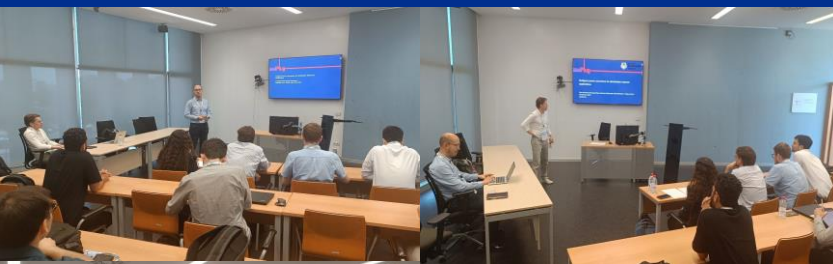

ELECTRIMACS 2024

In May 2024, the iPLUG project participated in the ELECTRIMACS conference organized in Castellon de la Plana, Spain. In particular, the iPLUG project organized a special session called "Multiport Power Converters for distribution network applications" where our colleagues from UoS, UPC and UNIPD presented the requirements and topologies about the multiport converter, their sizing methodologies and fault-ride through control structures for low voltage multiport converters.

Resiliency Day 2024

In March 2024, the iPLUG project participated in the Risk and Resiliency Day part of EPSRC Supergen Energy Networks Hub held in Newcastle upon Tyne, UK.

APEC 2024

In February 2024, the iPLUG project participated at the IEEE Applied Power Electronics Conference and Exposition (APEC) held in Long Beach, USA.

PUBLICATIONS

- A.C. Henao, A. Pepicciello, J.L. Domínguez-García, "Control Strategy for a Triple Active Bridge Converter: a Generalized Average Model Approach," Proceedings of 2023 IEEE PES Innovative Smart Grid Technologies Conference Europe, Grenoble, France, 2024, pp.1-5, doi: 10.1109/ISGTEUROPE56780.2023.10408694
- Ahmed Y. Farag, Davide Biadene, Paolo Mattavelli, Tarek Younis, "Three-phase Four-wire Bidirectional Y converter for an Enhanced Interface between the AC Grid and the Unipolar DC Microgrid," Proceedings of the 8th IEEE Workshop on the Electronic Grid (eGrid 2023), Karlsruhe, Germany, 2024, pp.1-6, doi: 10.1109/eGrid58358.2023.10380894

